

SAE 90L TO HB

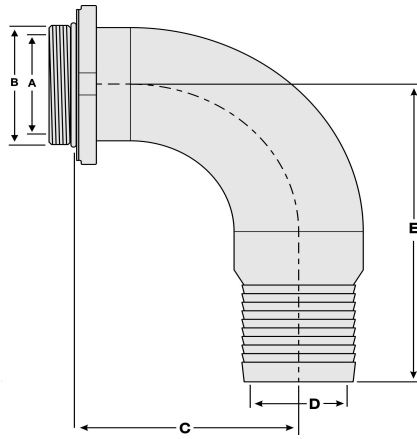

O-RING SEALED ADAPTER TO LONG RADIUS 90 DEGREES ELBOW TO HOSE BARB

SAE Split Flange Head to Barb							
Part Number SAE	Port Size	Dimensions IN					Lbs
		A	B	C	D	E	
20SAE-90L-20HB	1 1/4"	1.25	1 5/8 – 12	3.19	1.05	4.33	1.6
20SAE-90L-24HB	1 1/4"	1.25	1 5/8 – 12	3.19	1.29	4.38	1.7
24SAE-90L-20HB	1 1/2"	1.50	1 7/8 – 12	3.60	1.05	4.91	2.1
24SAE-90L-24HB	1 1/2"	1.50	1 7/8 – 12	3.60	1.29	4.91	2.1
24SAE-90L-32HB	1 1/2"	1.50	1 7/8 – 12	3.60	1.75	6.28	2.5
32SAE-90L-24HB	2"	2.00	2 1/2 – 12	4.35	1.29	6.18	3.3
32SAE-90L-32HB	2"	2.00	2 1/2 – 12	4.35	1.75	6.18	3.3
32SAE-90L-40HB	2"	2.00	2 1/2 – 12	4.35	2.25	7.85	4.2
32SAE-90L-48HB	2"	2.00	2 1/2 – 12	4.35	2.66	7.85	5.2
40SAE-90L-32HB	2 1/2"	2.50	3 – 12	5.08	1.75	7.13	5.7
40SAE-90L-40HB	2 1/2"	2.50	3 – 12	5.08	2.25	7.35	5.8
40SAE-90L-48HB	2 1/2"	2.50	3 – 12	5.08	2.66	8.18	6.3
48SAE-90L-32HB	3"	3.00	3 1/2 – 12	5.58	1.75	8.57	8.2
48SAE-90L-40HB	3"	3.00	3 1/2 – 12	5.58	2.25	8.27	8.2
48SAE-90L-48HB	3"	3.00	3 1/2 – 12	5.58	2.66	8.52	8.4
48SAE-90L-64HB	3"	3.00	3 1/2 – 12	5.58	3.63	10.24	10.1
64SAE- 90L-48HB	4"	4.00	4 1/2 – 12	7.35	2.66	10.62	14.7
64SAE- 90L-64HB	4"	4.00	4 1/2 – 12	7.35	3.63	10.96	15.4